

VACUUM  
QUICK-RELEASE  
VACUUM FITTINGS

---

G

- CeFiX Components, DN 16-63,  
DN 80-250, UHV .....G 39

## CHAIN CLAMPS

These are chains for quick connection of two tubes by means of tapered flanges. The tubes are centered by means of the inserted seals and a tight vacuum is ensured.

Due to the sturdy design, high compression strengths can be achieved and various types of metal seals used. A decisive aspect in many applications, tightening can be done evenly, with just one or two screws. Tightness is guaranteed once a certain tightening torque has been reached. When opening the chains, just one screw needs to be loosened to remove the chain - swift work ensured.

Since suitable materials are used, such connections are usually not any larger - and above all, they are lighter - than fixed flange couplings. There are various standard designs. The entire system is designed for a wide range of diameters and forces so that corresponding combination of standardized parts can cater to many special demands regarding to sealing force, excess pressure and materials.

### The main advantages of this system

- High tightening forces
- Even distribution of force
- Simple and swift assembly and removal
- Assembly possible even in places that is difficult to access
- Great flexibility of design
- Versatile use of various seals

### Range of applications

These chains are the preferred choice for:

- Vacuum technology and applications demanding the highest sealing tightness (metal seals)
- Locations subject to radiation (nuclear industry, accelerators, etc.) where radiation-proof seals and quick assembly are essential
- Connections that have to withstand high temperatures or baking (UHV connections, furnaces, etc.)
- Chemical industry (corrosion resistant design), petrochemical industry
- Cryogenics
- Generally for connections with medium to large diameters
- Customized designs for critical applications (restricted space, pressure, etc.)
- Securing of units or assemblies with or without sealing but respective center rings (securing of filters, valves, etc.)

The application range is virtually limitless. The maximum diameter depends on requirements and is between 500 and 700 mm.

There are various materials for various purposes, such as antimagnetic systems made from Aluminum and Stainless Steel.

MATERIALS	RANGE OF APPLICATIONS
Plastic high-temperature	-20... +100°C, (150°C short time), antimagnetic, only for elastomer seals, electric insulation, suitable for cleanrooms, for glass and metal flanges
Plastic ultra high-temperature	-20... +200°C, (220°C short time), only for elastomer seals, electric insulation, antimagnetic, suitable for cleanrooms, for glass and metal flanges
Aluminum BX Type* with knob (1 catch)	-271... +150°C, suitable for cleanrooms, antimagnetic, only for elastomer seals
Stainless Steel (1 catch)	-271... +350°C, cryogenics, antimagnetic, radiation resistant, only elastomer seals
Stainless Steel (2 screws)	-271... +350°C, cryogenics, antimagnetic, radiation resistant, metal and elastomer seals
Plastic standard	-20... +60°C, (80°C short time), antimagnetic, only for elastomer seals, electric insulation, suitable for cleanrooms, for glass and metal flanges
Cast Aluminum	-20... +100°C, antimagnetic, only for elastomer seals, suitable for cleanrooms
Forged Aluminum	-271... +150°C, cryogenics, antimagnetic, for metal and elastomer seals, radiation resistant
Nickel plated Steel	-271... +350°C, cryogenics, pressure, radiation resistant, for metal and elastomer seals
Stainless Steel (CeFiX)	-271... +350°C, cryogenics, pressure, antimagnetic, radiation resistant, for elastomer and metal seals

\*BX Type (4 contact per link) patented.

## SEALS

**Neyco provides several types of seals, as following:**

- Seals with center rings on the inside or outside made from various elastomer materials
- Seals with center rings on the inside or outside as Aluminum edge seals with various cross-sections
- Moulded seals in various shapes and sizes, Aluminum
- CeFiX seals for UHV applications in Aluminum, Copper or Nickel
- CeFiX seals in various shapes and sizes, Aluminum

MATERIALS	RANGE OF APPLICATIONS
Teflon/Viton	Suitable for cleanrooms, electric insulation, leak rate: $<1.10^{-9}$ mbar.l.s <sup>-1</sup> , antimagnetic, -20... +200°C
Teflon/FEP	Suitable for cleanrooms, electrical insulation, leak rate: $<1.10^{-6}$ mbar.l.s <sup>-1</sup> , antimagnetic, chem./corrosion, -50... +200°C
Aluminum/Viton	Suitable for cleanrooms, pressure, antimagnetic, leak rate: $<1.10^{-9}$ mbar.l.s <sup>-1</sup> , -20... +200°C
Stainless Steel/Viton	Pressure, suitable for cleanrooms, leak rate: $<1.10^{-9}$ mbar.l.s <sup>-1</sup> , antimagnetic, -20... +200°C
Stainless Steel/Kalrez	Excellent chem. /corrosion, suitable for cleanrooms, antimagnetic, leak rate: $<1.10^{-9}$ mbar.l.s <sup>-1</sup> , -10... +315°C
Aluminum	Antimagnetic, radiation resistant, cryogenics, temperature range: -271... +150°C leak rate: $<1.10^{-11}$ mbar.l.s <sup>-1</sup>
OFS* Copper/ OFS* Copper Silver plated	Radiation resistant, antimagnetic, pressure, temperature range: -271... +350°C, cryogenics, leak rate: $<1.10^{-11}$ mbar.l.s <sup>-1</sup>
Nickel	Antimagnetic, radiation resistant, cryogenics, temperature range: -271... +150°C leak rate: $<1.10^{-11}$ mbar.l.s <sup>-1</sup>

\*OFS: Oxygen-free, silver-alloyed copper for higher thermal stability.

## FLANGES

Flanges can be used with chain clamps and elastomer seals or with metal seals for UHV applications.

Neyco provides several systems: KF, ISO-Tapered™, CeFiX



- Temperature: -271°C to +300°C (304), -271°C to +350°C (316L)
- Leak rate:  $<1.10^{-9}$  mbar.l.s<sup>-1</sup>
- Antimagnetic, cryogenics

**KF / ISO-Tapered™ Systems (metal)**

- Materials: Stainless Steel 304/ Stainless Steel 316L

**Advantages**

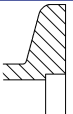
- Space-saving, quick connections
- Exceedingly high vacuum tightness
- Temperature- and radiation-resistant designs
- Antimagnetic designs
- Even distribution of force
- Rotary connection

DRAWING	FLANGE TYPE	FLANGE MATERIAL	SEALS	SEALING SURFACE	CLAMPING MEANS
	KF DN 10 to 63	Aluminum Stainless Steel Glass	Elastomer Aluminum (Copper)	Unprotected	Chain clamps (1 screw)
	ISO-Tapered DN 80 to 250	Aluminum Stainless Steel Glass	Elastomer Aluminum	Unprotected	Chain clamps (1 or 2 screws)
	EVAC-CeFiX DN 80 to 250	Aluminum Stainless Steel	Elastomer Aluminum Copper Nickel	Protected No cutting edge	Chain clamps

**CeFiX systems**

The most striking feature of the CeFiX flange compared to the CF flange is the lack of a cutting edge. The edge is easily damaged and requires high sealing forces and has therefore been omitted with the CeFiX system.

The seals are designed in such a way that they seal on the 20 degree taper of the flange, thereby reducing the necessary sealing force by up to 50 %. Since the dimensions of the

sealing groove of both systems are absolutely identical, the CeFiX seal can also be used for standard CF flanges. So the seal can also be used for flanges with slightly damaged flange edges.

Thanks to the reduced sealing force, Nickel alloys can also be used, but just for CeFiX flanges, since standard CF flanges could be damaged.

**Comparison of sealing force (N/mm sealing length)**

	CeFiX	STANDARD
Aluminum	70	100
Copper	220	410
Nickel	400	680

- Materials: Stainless Steel 316L
- Temperature: -271°C to +350°C
- Leak rate: <math> < 1.10^{-11} \text{ mbar.l.s}^{-1} </math>
- Antimagnetic, cryogenics, suitable for UHV, excess pressure, resistant to chemicals

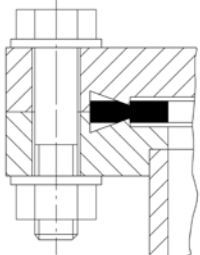
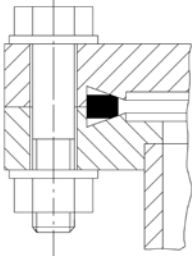
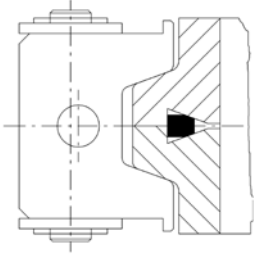
STANDARD CF CONNECTION	CeFiX SEAL WITH CF FLANGES	CeFiX SEAL CHAIN CLAMP WITH SPECIFIC FLANGES
Sealing force 100%	Sealing force 50%	Sealing force 50%
		

## BELLOWS AND HOSES

### Advantages

- Highly flexible, without annealing
- Highest bending and torsion strength
- Can be used for ultra-high vacuum to slight pressure
- Bakeable, suitable for cryogenics
- Radiation resistant, antimagnetic
- Perfect to clean (ultrasound)
- Optimum corrosion resistance
- Minimum outgassing

### Behaviour under pressure

Metal bellows and tubes are used for vacuum, excess pressure and on both sides.

If subjected to excess pressure, the bellows and tubes tend to elongate or - in the case of tightly clamped flanges - to buckle.

### Applications

- Compensation of axial, lateral or angular set-offs
- Prevention of vibration transfer
- Substitute for elastomer compensators
- Compensate thermal expansion

### Metal bellows and hoses

- Materials: Stainless Steel 304 (flanges), Stainless Steel 316Ti (bellows), Stainless Steel 316L (hoses)
- Temperature: -200°C to +350°C
- Leak rate:  $<1.10^{-9}$  mbar.l.s<sup>-1</sup>
- Antimagnetic, cryogenics, radiation resistant, suitable for clean rooms, usable with metal or elastomer seals

### Teflon bellows

 See Section H - Glass & Quartz Components in this catalogue.

All given dimensions are nominal in mm.



Chain clamps



Metal bellows

# CeFiX Components, DN 16-63, DN 80-250, UHV

## CeFiX FLANGES, CeFiX BLANKING PLATES

### APPLICATIONS

- UHV applications up to  $10^{-11}$  mbar
- Pressurized applications up to 100 bar
- Cryogenics applications down to  $-270^{\circ}\text{C}$
- Oven applications up to  $350^{\circ}\text{C}$  (Cu seals),  $450^{\circ}\text{C}$  (Ni seals)
- Flange seals reusable up to 10 times (provided no scratches)
- 316L Stainless Steel for nuclear and military applications

### CeFiX FLANGES, DN 16-63, STAINLESS STEEL 316L

DN	A	B	C	D	L	P/N
16	30	21.4	16	20	22	32.016005.631.316
25	40	32.9	24	28	22	32.025005.631.325
40	55	48.3	40	44.5	27	32.040005.631.340
50	75	61.8	50	57	30	32.050005.637.350
63	87	82.5	70	76	30	32.063005.631.363

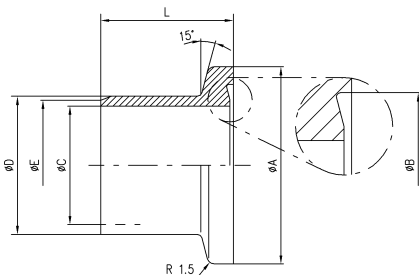

### CeFiX FLANGES, DN 80-250, STAINLESS STEEL 316L

DN	A	B	C	D	D1	X	P/N
80	104.8	91.60	76.5	82.6	86	20	32.080005.531.308
100	134.0	120.65	100	108.4	117	20	32.100005.531.310
160	190.0	171.45	150	159.3	168	20	32.160005.531.316
200	242.0	222.30	200	205.3	218	25	32.200005.531.320
250	292.0	273.15	250	256.3	270	30	32.250005.531.325

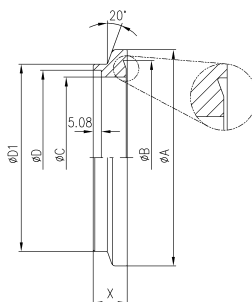

### CeFiX BLANKING PLATES, DN 16-63, STAINLESS STEEL 316L

DN	A	B	P/N
16	30	21.4	32.016005.640.316
25	40	32.9	32.025005.640.325
40	55	48.3	32.040005.640.340
50	75	61.8	32.050005.640.350
63	87	82.5	32.063005.640.363

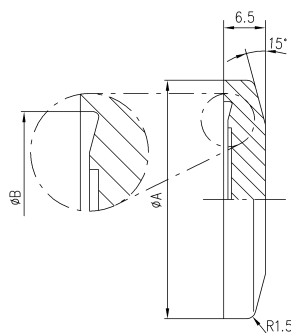

### CeFiX BLANKING PLATES, DN 80-250, STAINLESS STEEL 316L

DN	A	F	P/N
80	104.8	9.0	32.080005.540.308
100	134.0	12.5	32.100005.540.310
160	190.0	13.5	32.160005.540.316
200	242.0	13.5	32.200005.540.320
250	292.0	14.0	32.250005.540.325

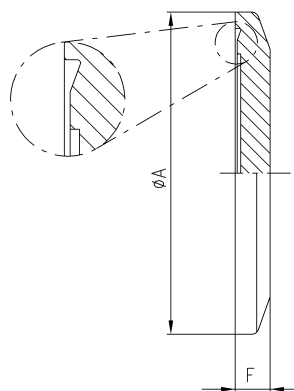

## CeFiX FITTINGS

### APPLICATIONS

- UHV applications up to  $10^{-11}$  mbar
- Pressurized applications up to 100 bar
- Cryogenics applications down to  $-270^{\circ}\text{C}$
- Oven applications up to  $350^{\circ}\text{C}$  (Cu seals),  $450^{\circ}\text{C}$  (Ni seals)
- Flange seals reusable up to 10 times (provided no scratches)

### CeFiX ELBOWS, DN 16-63, STAINLESS STEEL 316 L

DN	X	P/N
16	38	33.016005.651.316
25	52	33.025005.651.325
40	63	33.040005.651.340
50	82	33.050005.651.350
63	105	33.063005.651.363

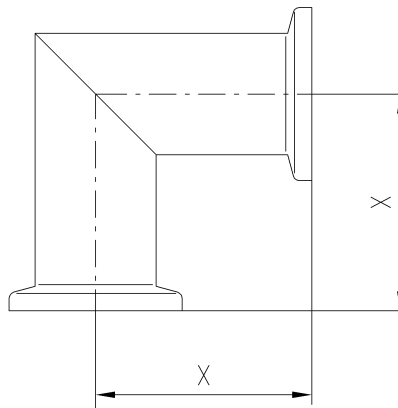

### CeFiX TEES, DN 16-63, STAINLESS STEEL 316 L

DN	X	L	P/N
16	38	76	33.016005.661.316
25	52	104	33.025005.661.325
40	63	126	33.040005.661.340
50	82	164	33.050005.661.350
63	105	210	33.063005.661.363

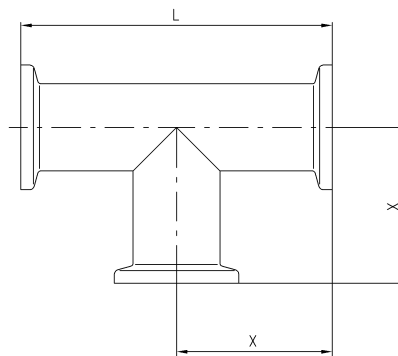



### CeFiX CROSSES, DN 16-63, STAINLESS STEEL 316 L

DN	X	L	P/N
16	38	76	33.016005.671.316
25	52	104	33.025005.671.325
40	63	126	33.040005.671.340
50	82	164	33.050005.671.350
63	105	210	33.063005.671.363

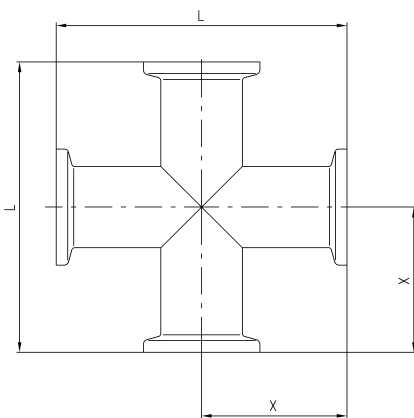

### CeFiX TO CF ADAPTORS, DN 16-63, STAINLESS STEEL\*

DN	A	B	X	P/N
16	30	34	30	33.016003.68A.301/01
25	40	54	45	33.025003.68A.302/02
40	55	70	45	33.040003.68A.304/04
50	75	86	50	33.050003.68A.305/05
63	87	114	60	33.063003.58A.306/06

\*304/316 L

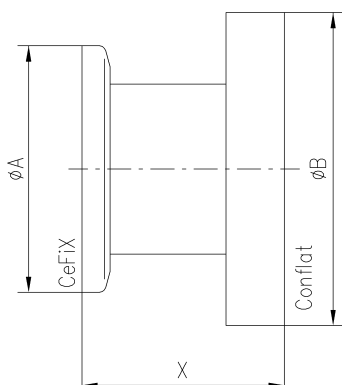

### CeFiX ELBOWS, DN 80-250, STAINLESS STEEL 316 L

DN	X	P/N
80	110	33.080005.552.308
100	135	33.100005.552.310
160	167	33.160005.552.316
200	210	33.200005.552.320
250	254	33.250005.552.325

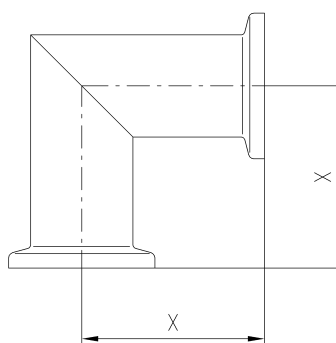

### CeFiX TEES, DN 80-250, STAINLESS STEEL 316 L

DN	X	L	P/N
80	110	220	33.080005.562.308
100	135	270	33.100005.562.310
160	167	334	33.160005.562.316
200	210	420	33.200005.562.320
250	254	508	33.250005.562.325

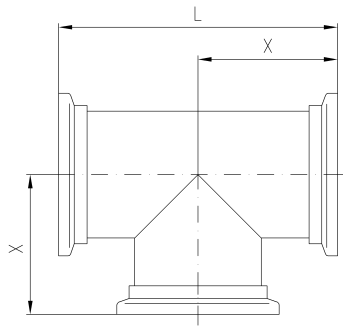

### CeFiX CROSSES, DN 80-250, STAINLESS STEEL 316 L

DN	X	L	P/N
80	110	220	33.080005.572.308
100	135	270	33.100005.572.310
160	167	334	33.160005.572.316
200	210	420	33.200005.572.320
250	254	508	33.250005.572.325

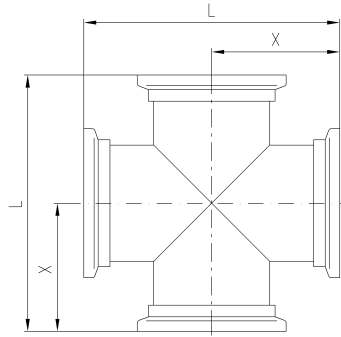

### CeFiX TO CF ADAPTORS, DN 80-250, STAINLESS STEEL\*

DN	A	B	X	P/N
100	134	152	80	33.100003.58A.310/10
160	190	203	86	33.160003.58A.316/16
200	242	254	90	33.200003.58A.320/20
250	292	305	90	33.250003.58A.325/25

\*304 / 316 L

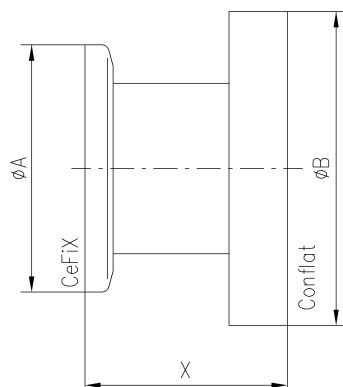



**neyco**

30 avenue de la Paix  
92170 VANVES - France  
Tel: +33(0)1 41 90 50 50  
Fax: +33(0)1 41 90 50 51  
[www.neyco.fr](http://www.neyco.fr)



Vacuum G 2013-4

**neyco**