

Edge™ CDG100D2 - 100°C (F.S.R. 1 ... 1000 Torr / mbar)

Edge™ CDG100D2 - 100°C - Hot Inside, Small Outside

INFICON Edge Capacitance Diaphragm Gauge is a highly accurate vacuum measurement instrument designed for harsh manufacturing environments. The proven temperature controlled, corrosion resistant, ultra-pure ceramic sensor provides superior span stability over many years paired with state-of-the-art zero stability. Edge comes with the INFICON patented unique sensor shield which protects the gauge from undesired process by-products. Advanced electronics offer a wide range of configurable signal conditioning for all applications and optional EtherCAT fieldbus interface. The innovative heating concept enables a cool to the touch surface and saves valuable tool space. INFICON Edge is the smallest vacuum measurement instrument of its kind.



ADVANTAGES

- Compact, saves valuable tool space
- Easy integration, EtherCAT, wide variety of full scales and flanges, standard with two set points
- Easy one push button or remote signal zero command, zero offset adjustable
- Diagnostic port for quick service and maintenance
- Two year warranty, longer life time with advanced heating concept and gauge protection
- No long term recalibration due to excellent signal stability and repeatability, even in harsh plasma applications
- Compliance & standards: CE, EN, UL, SEMI, RoHS

ORDER INFORMATION

ORDERING INFORMATION

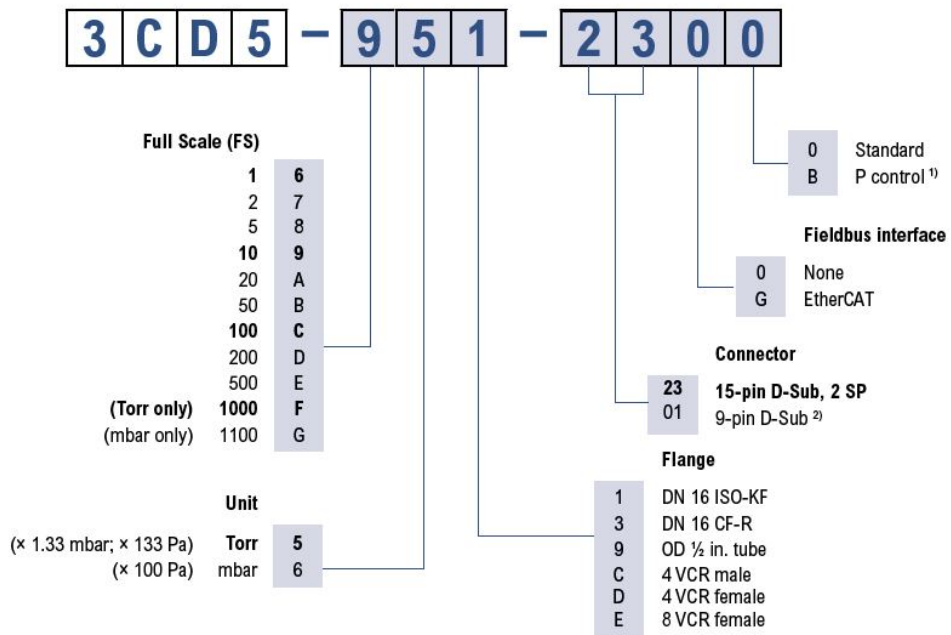

1) Optimized signal filter setting for pressure control

2) Not possible with fieldbus interfaces

bold = standard products

Other flange types on request.

SPECIFICATIONS

Type		1000 ... 500 Torr / mbar	200 ... 1 Torr / mbar
Accuracy (1)	% of reading	0.15	0.15
Temperature effect on zero	percent FS/°C	0.0025	0.0025
Temperature effect on span	% of reading / °C	0.02	0.02
Pressure, max.	kPa (absolute)	400	260
Resolution	percent FS	0.003	0.003
Lowest reading	percent FS	0.01	0.01
Lowest suggested reading	percent FS	0.05	0.05
Lowest suggested control pressure	percent FS	0.5	0.5
Temperature			
Sensor	°C	100	100
Operation (ambient) (5)	°C	+10 ... +50	+10 ... +50
Bakeout at flange	°C	≤110	≤110
Storage	°C	-20 ... +65	-40 ... +65
Supply voltage		+14 ... +30 VDC or ±15 V (±5%)	+14 ... +30 VDC or ±15 V (±5%)
Power consumption			
During Heat up	W	≤20	≤20
At operating temperature	W	≤14	≤14
Output signal (analog)	V (dc)	0 ... +10	0 ... +10
Response time (2)	ms	30	30
Degree of protection		IP 40	IP 40
Standards			
CE conformity		EN 61000-6-2/-6-3, EN 61010 & RoHS	EN 61000-6-2/-6-3, EN 61010 & RoHS
ETL certification		UL 61010-1, CSA 22.2 No.61010-1	UL 61010-1, CSA 22.2 No.61010-1
SEMI compliance (5)		SEMI S2	
SEMI compliance			SEMI S2
Electrical connection		D-sub, 15 pole, male	D-sub, 15 pole, male
Setpoint			
Number of setpoints		2 (SP1,SP2)	2 (SP1,SP2)
Setpoint			

SPECIFICATIONS

Type		1000 ... 500 Torr / mbar	200 ... 1 Torr / mbar
Relay contact	V (dc)	≤30	≤30
Setpoint			
Relay contact	A (dc)	≤0.5	≤0.5
Setpoint			
Hysteresis	percent FS	1	1
Diagnostic port			
Protocol		RS232-C	RS232-C
Read		pressure, status, ID	pressure, status, ID
Set		set points, filter, zero adjust, factory reset, DC offset	set points, filter, zero adjust, factory reset, DC offset
Materials exposed to vacuum			
		Aluminum oxide ceramic (Al ₂ O ₃), stainless steel (AISI 316L ⁽⁴⁾)	Aluminum oxide ceramic (Al ₂ O ₃), stainless steel (AISI 316L ⁽⁴⁾)
Internal volume			
I. volume 1/2" tube	cm ³ (in. ³)	4.2 (0.26)	4.2 (0.26)
I. volume DN 16 ISO KF	cm ³ (in. ³)	4.2 (0.26)	4.2 (0.26)
I. volume DN 16 CF-R	cm ³ (in. ³)	4.2 (0.26)	4.2 (0.26)
I. volume 8 VCR®	cm ³ (in. ³)	4.2 (0.26)	4.2 (0.26)
Weight			
Weight 1/2" tube	g	837	837
Weight DN 16 ISO KF	g	852	852
Weight DN 16 CF-R	g	875	875
Weight 8 VCR®	g	897	897
EtherCAT			
Protocol EtherCAT		protocol specialized for EtherCAT	protocol specialized for EtherCAT
Communication standards		ETG.5003.1 S (R) V1.1.0 Common Device Profile ETG.5003.2080 S (R) V1.3.0 Specific Device Profile: Vacuum Gauge	ETG.5003.1 S (R) V1.1.0 Common Device Profile ETG.5003.2080 S (R) V1.3.0 Specific Device Profile: Vacuum Gauge
Node address		Explicit Device Identification	Explicit Device Identification
Physical layer		100BASE-Tx (IEEE 802.3)	100BASE-Tx (IEEE 802.3)
Digital functions read		pressure, status, ID	pressure, status, ID
Digital functions set		set points, filter, zero adjust, reset, DC offset	set points, filter, zero adjust, reset, DC offset

SPECIFICATIONS

Type		1000 ... 500 Torr / mbar	200 ... 1 Torr / mbar
Mailbox (CoE)		SDO requests, responses and information	SDO requests, responses and information
Process data		Fixed PDO mapping and configurable PDO mapping	Fixed PDO mapping and configurable PDO mapping
EtherCAT connector		2 x RJ45, 8-pin (socket), IN and OUT	2 x RJ45, 8-pin (socket), IN and OUT
Cable		shielded Ethernet CAT5e or higher	shielded Ethernet CAT5e or higher
Connector for CDG (analog output, supply voltage, setpoints)		D-sub, 15 pin, male	D-sub, 15 pin, male
EtherCAT			
Data rate	Kbps	100000	100000
EtherCAT			
Cable length	m (ft.)	≤100 (330)	≤100 (330)

(1) Non-linearity, hysteresis, repeatability at 25 °C ambient operating temperature without temperature effects after 2 hours operation.

(2) Increase 10 ... 90 percent FS

(3) For pressure control type only

(4) 18% Cr, 10% Ni, 3% Mo, 69% Fe

(5) Ambient temperatures > 40°C may increase surface temperature above SEMI S2 compliance levels

DIMENSIONS

mm (inch)

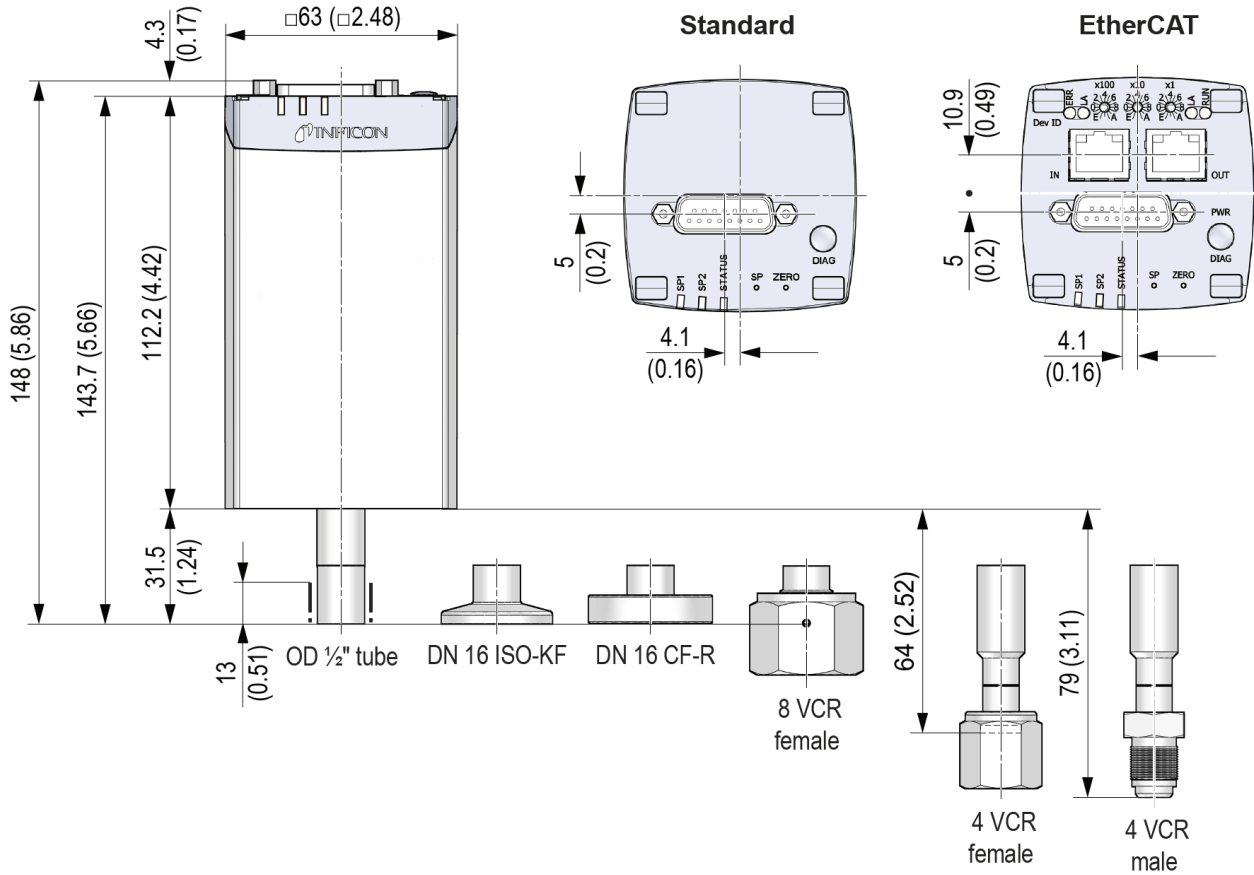

www.inficon.com reachus@inficon.com

Due to our continuing program of product improvements, specifications are subject to change without notice. RateWatcher is a trademark of INFICON. All other trademarks are the property of their respective owners.

(2021-08) © 2021 INFICON